

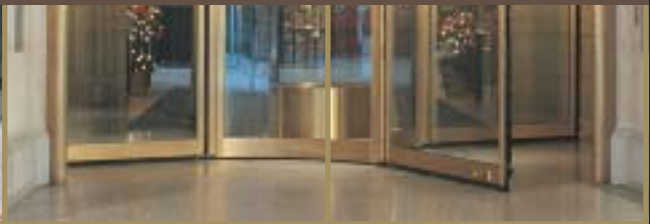

(XL)

XL Revolving Doors

(XL)



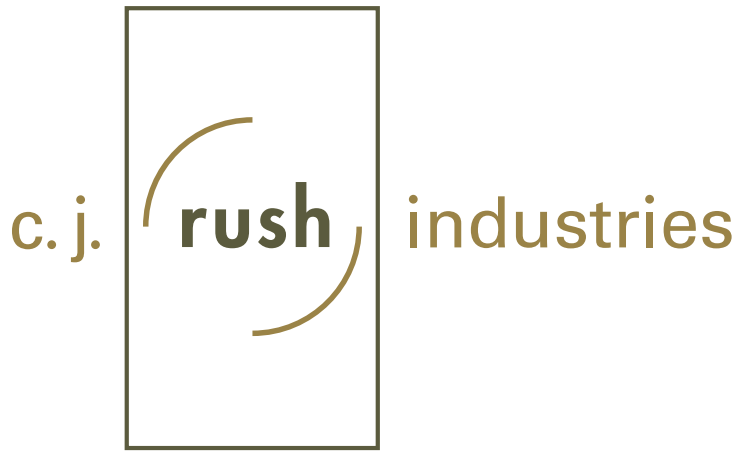

XL Revolving Doors

Extra Large Revolving Doors offer optimum flow of traffic with cargo. These doors are designed to offer maximum ease of passage while maintaining the HVAC integrity of the building. "Always open and always closed"

Series 5500 is a four-wing carousel style door most often used for prestige entrances of hotels and office buildings. Fully automatic with comprehensive safety features, these doors have the capacity of processing up to 4800 persons per hour in each direction.

Series 6500 is a two-wing design with centre swing doors for emergency egress. These doors are optimally functional for transportation and institutional application where optimum flow of volume and passage of luggage or emergency gurneys is required. Fully programmable operation and safety features make this a truly efficient solution.

Series 5500 XL Revolving Doors



Large Diameter Carousel Style four-wing design. Choose entrances from 12' (3600mm) to 16' (4800mm) diameter. Automated for maximum safety using multi motion sensors. Wings can be easily collapsed to provide unobstructed emergency exits from both sides of the carousel.

Glazed centre carousel may be used for display. Ideal for hotels, airports, office buildings and department stores. This series includes many standard features.

Features:

Automatic 1 - When a person approaches the Series 5500 door they are detected by the Motion Detectors and the door begins to revolve at a speed of approximately 4 RPM. After a preset time (passage time) the system switches to the idling speed of approximately 1 RPM and then stops at the quarter-point position.

Automatic 2 - As "Automatic 1", but the door revolves continuously at the idling speed of approximately 1 RPM without activation by persons, so that the direction of passage is indicated.

Features: continued

Locked or Off Position - The Series 5500 door turns at idling speed to the quarter-point position and stops there. The two outer door wings can be locked manually if desired.

Open Position - If, in warm weather, while cleaning, or when transporting large articles or wheeled trolleys, a clear passage is required, the control switch is turned to stop. The four wings are then collapsed against the central carrousel where they are secured by an automatic holding device.

Emergency Egress - In the case of emergency, all four wings can be opened towards the outside. Two escape routes arise as follows:
3'-3 3/8" (1000mm) on a 12' (3600mm) revolving door,
3'-10" (1170mm) on a 14' (4200mm) revolving door,
4'-4 3/4" (1340mm) on a 16" (4800mm) revolving door.

The 4 door wings are mounted on pivot bearings and are held in the form of a cross by spring force. They can be folded back at any time towards or away from the direction of walking, e.g. in an emergency situation (see Open Position above) door wings fold back and are held against the centre carrousel. The system halts when the door wings are pushed forward approximately 10 degrees or pressed back 5 degrees.

Safety Features:

Emergency Stop Button - the revolving door can be stopped at any time by pressing the EMERGENCY STOP button located on the corner posts.

Handicap Button - Unsure or handicapped persons, for whom the walking speed appears too fast, can push the handicap button. The door then revolves for a separate preset time at a reduced speed of approximately 2 RPM (adjustable for one revolution), then returns to normal operating speed.

Safety Features: continued

Safety 'Ceiling' Sensors - the photo optic safety sensors are mounted in the ceiling by the entry and exit. They are activated when the revolving door wings are approximately 20" (50cm) from the corner post. If the beam is broken by a late entering pedestrian the rotation will stop immediately.

Safety 'Heel' Sensors - A safety sensor is mounted on the bottom rail of the trailing door leaf. If one of these sensors responds detecting a slow moving person, the system is immediately switched to "stop function". When clear, the door rotation will revert to normal speed, (this is to protect area near centre core).

Safety 'Overhead' Sensors - The safety sensor strips are mounted on the top frame section of all 4 door wings. The sensors are placed sloping downwards approximately 5° and scan a safety zone in front of the revolving door wing. If a person is detected in this safety zone, e.g. when walking slowly, the revolving door changes back from walking speed to the idling speed or a "stop function" is initiated.

Electromagnetic Brake - To release the breaking power in an emergency situation such as safety sensors tripped or doors folded, the electromagnetic brake unit is used.

Torque-Limitation Device - Force required to stop rotation of the door is limited to a force not greater than can be applied by one person. Computer measured rotation speed is monitored to detect any obstrutational resistance on the door.

Series 6500 XL Revolving Doors



Large Diameter two-wing style. The two-wing design has no centre shaft, but two swing doors that break away in emergency situations. This door comes in 10' (3050mm), 12' (3600mm), 14' (4200mm) and 16' (4800mm). The design is most effectively used for high volume traffic areas and can accommodate luggage carts, wheelchairs, and ambulance stretchers. The door allows 5700 people per hour.

Features:

Operating Switch Position "Off" – The door turns into locking position and locks automatically. All sensors are switched off. Emergency and optional showcase safety wings serve as night lock.

Operating Switch Position "Automatic" – The door turns into starting position and begins to move in fast speed as soon as the motion detector is activated. If the motion detector is not activated again, the door turns 360° changes then into creep speed and stops finally in the starting position.

Features: continued

Operating Switch Position "Permanent" – The door turns continuously at slow speed. It accelerates to a fast speed as soon as a person enters the detection area of the motion detector. If the motion detector is not activated again, the door turns 360° until reaching starting position and changes afterwards again to a slow speed.

Operating Switch Position "Winter" – The door stops in the closed position to better protection from the elements.

Operating Switch Position "Hand" – In the operating switch position "HAND", the door turns to escape position and can be moved by using the handicapped button. All sensors are switched off.

Function In Case of Power Failure – In operating switch position "OFF" or "HAND", the door remains in the actual position. When using the door-open push-button (green), the door turns at slow speed into escape position. The lock of the swing-door leaves unlocks and the door leaves can be opened manually. The state of the integrated battery is surveyed continually. When power resumes, an electronic restart-lock is activated. This is indicated on the IBS-error display. In order to normalize the door, the operating switch must be turned from position "OFF" to position "AUTO" or the door-open switch has to be used. The door then starts with its program and "searches for" the locking position in creep speed. Afterward, the door is ready for service.

Handicapped Buttons – When using the handicapped buttons in operating switch position, "AUTOMATIC" or "PERMANENT", the door turns at least 360° at slow speed, although the detection area of the motion detector is entered.

Door-start Push Buttons – When using this push button inside the drum enclosure, the door turns 360°. Thus it is impossible for any person(s) to become trapped inside the door.

Features: continued

Emergency-Off Switch (red) – When the emergency-off switch is used, the motors are switched off. The door stops immediately.

Door-open push button (green) – Using this push button, the door begins to turn immediately into escape position (also after a power failure), irrespective of the operating switch position. The swing door wings can now be opened manually.

Safety Features:

Emergency Exit Button – 105 cmø **Handicapped Button** – 85 cmø

Door Pressure Recognition – An integrated recognition of the door pressure stops the revolving door for 3 seconds, when the adjusted value has been exceeded.

Safety Contact Strips For Heel Protection – At the bottom of the door wings, horizontal safety strips for heel protection are installed. When touching these strips the door stops immediately. If the contact to the strips is released, the door starts turning again.

Safety Contact Strips At Drums – Between the rotating door-wings and the leading fixed-edge of the drum enclosure, shearing edges can occur. Therefore, safety strips are installed at the edges of the drums. They are pressure activated. When the strips are activated, the door stops immediately and then rotates slowly in reverse to provide additional exit space. After deactivation, the door starts to turn again automatically.

Escape Swing Doors – In case of emergency, by using the door-open switch, the two swing doors are unlocked and can be opened. The door begins to turn immediately into escape position, irrespective of the operating switch position.

Safety Features: continued

Photoelectric Sensor at Drums – Between rotating door wings and fixed drums, shearing edges can occur. Therefore photo-sensors are installed at the edges of the drums. They are enabled, if only an adjustable distance between the sliding wing and the edges of the drum is left. When the sensors are activated, the door stops immediately. After deactivation, the door starts to turn again automatically.

Sensor for Heel Protection – In the bottom part of the door wings, additional horizontal safety photo-sensors are integrated, which serve as heel protection. When the sensors are activated, the door goes into creep speed. After deactivation, the door starts to turn at full speed again.

Curved Sliding Wing – At the end of the door wings, a curved sliding wing (in rotation direction) is fixed.

The safety contact strips on the drums, as well as the safety switch of the sliding wing and the photo-sensors provide triple safety for the rotating wing edges.



66

Lee Interior Design

5500 Series XL Diameter
Revolving Door

Fully automatic operation with
safety sensor controls and
handicap access.
Satin Brass Finish

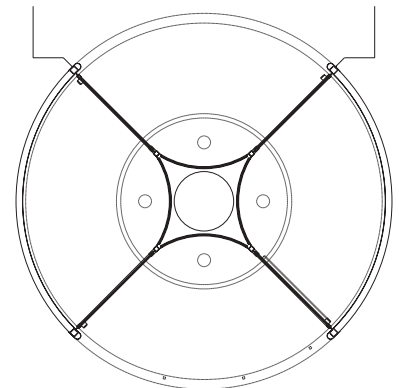



64

Lee Interior Designs

5500 Series XL Diameter
Revolving Door

Fully automatic operation with
safety sensor controls and
handicap access.
Satin Brass Finish

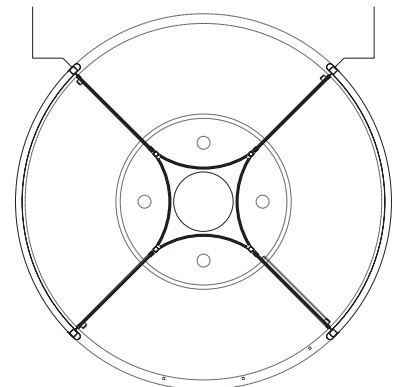



8

5500 Series XL Diameter
Revolving Door

Fully Automatic operation with
safety sensor controls and
handicap access.
Stainless Steel Mirror Finish

Zeidler Roberts Partnership Architects

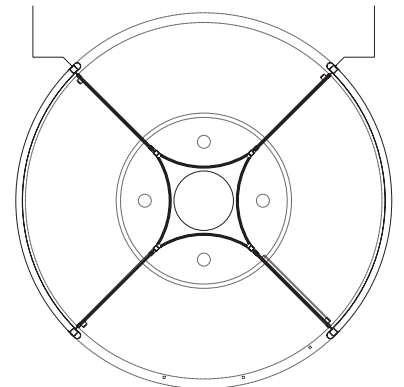



63

5500 Series XL Revolving Door

Fully Automatic operation with safety sensor controls and handicap access.
Stainless Steel Mirror Finish

Bregman + Hamann Architects

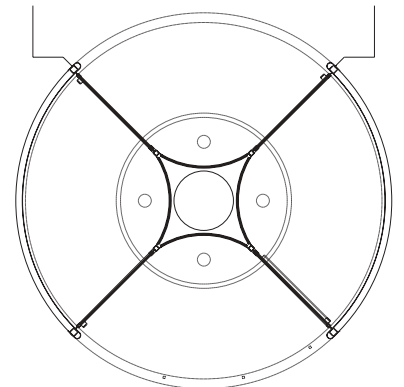



72

6500 Series XL Diameter
2-Wing Revolving Door

Fully Automatic operation with
safety sensor controls and
handicap access.

Parkin Architects

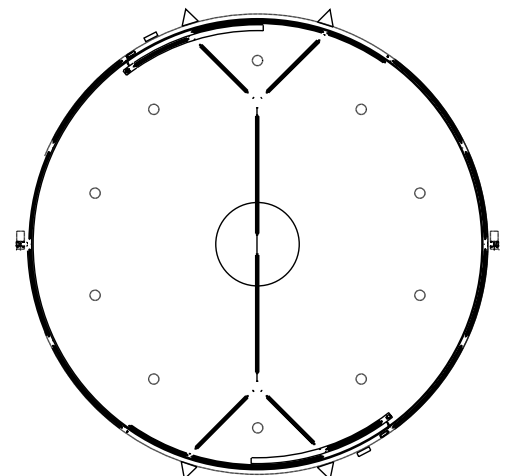

(x-1) 13-06/03



65

Parkin Architects

6500 Series XL Diameter
2-Wing Revolving Door

Fully Automatic operation with
safety sensor controls and
handicap access.

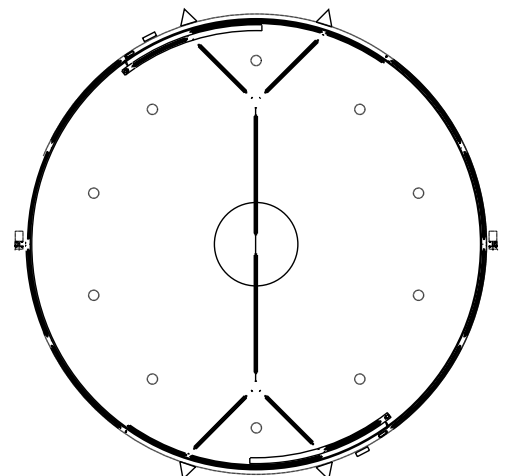

(x-1) 14-06/03